

# ALPRO® ACOUSTICAL SYSTEMS

DECORATIVE NOISE REDUCING SOLUTIONS FOR WALLS AND CEILINGS

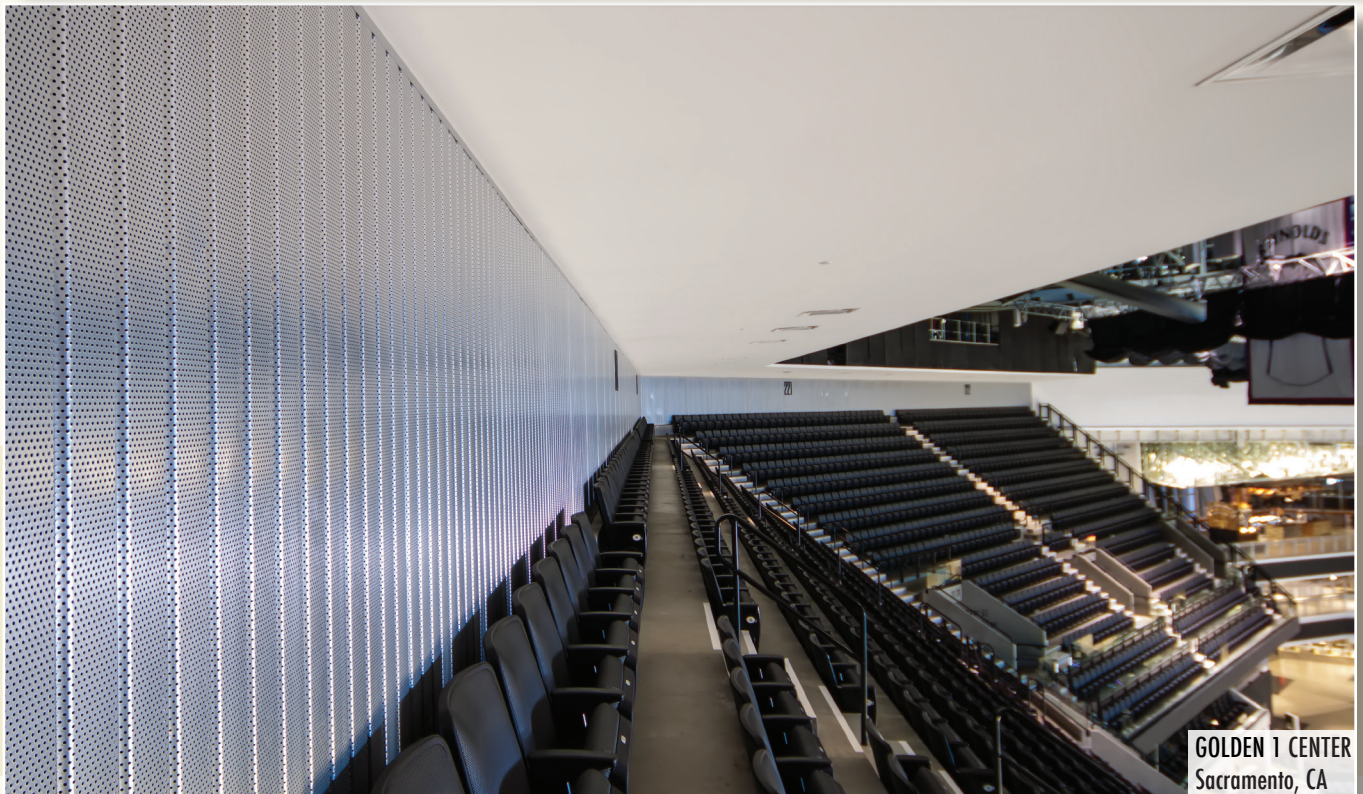

SMU TENNIS CENTER  
Dallas, TX



GOLDEN 1 CENTER  
Sacramento, CA



# ALPRO® ACOUSTICAL SYSTEMS

With over 60 years of experience, ALPRO® ACOUSTICAL SYSTEMS sets the standard for effective noise reduction solutions that are attractive, economical, and suitable for any environment. ALPRO's comprehensive line of acoustical products are manufactured from perforated metals that are formed, assembled, and finished to create systems of high performance and premium aesthetics. ALPRO ACOUSTICAL SYSTEMS applies a total systems approach to the design and manufacture of products for the management of noise and reverberation time in new construction, renovation, and retrofit projects.

## ADVANTAGES OF METAL ACOUSTICAL SYSTEMS

- Excellent noise reduction qualities
- Maximum durability and abuse resistance
- Non-combustible – 'Class A' flame spread rating
- Low maintenance; easy to clean
- Economical and affordable alternative to other materials
- Numerous color and custom finish options
- Suitable for interior and exterior applications
- Available in smooth or embossed surfaces
- Unperforated, non-acoustical panels are also available.

## ALPRO ADVANTAGES

- OPTIMAL ACOUSTICAL PERFORMANCE – Tested NRC ratings of 1.00 and above
- 10 CORRUGATION PATTERNS
- MARK-7 Linear Panels
- FINISHES
  - Post-fabrication powder coating guarantees total surface coverage and maximum protection against corrosion.
  - 12 stock colors in standard and premium powder coat finishes
  - 12 stock colors in our exclusive, enhanced durability ACROGUARD® powder coat finishes
  - 12 stock colors in our exclusive, durable exterior ACROGUARD®-UVX powder coat finishes
  - ACROSTAT™ anti-microbial powder coat for life-time protection against biological growth
  - Custom color match capability
- TOTAL SYSTEMS SOLUTIONS FROM A SINGLE SOURCE
- AWARD WINNING CUSTOM DESIGN CAPABILITY – ALPRO's design professionals are always available to help architects and designers realize their visions for uniquely expressive and functional designs.
- Contributes to LEED® credits – Our Eco-Philosophy and commitment to "green" design and manufacturing practices are unequaled in our industry.



CORRUGATION PATTERNS

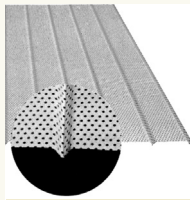

**PATTERN A**

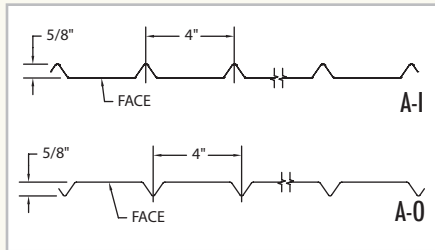

**PATTERN E**

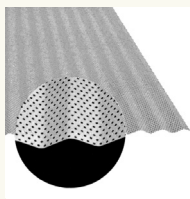
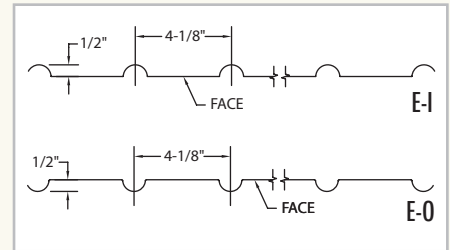

**PATTERN B**

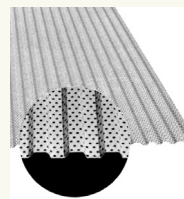
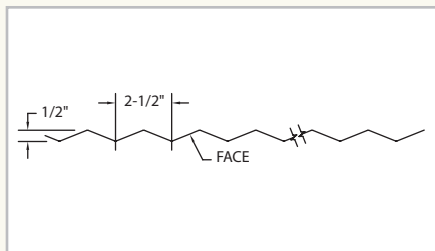

**PATTERN F**

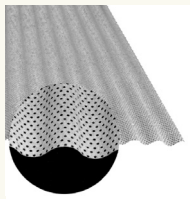
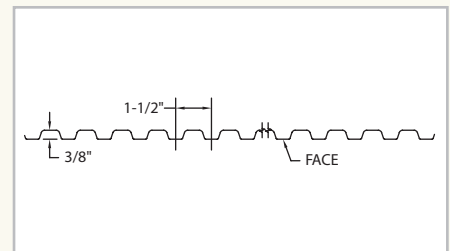

**PATTERN C**

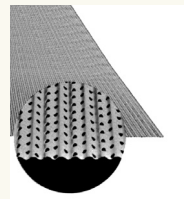
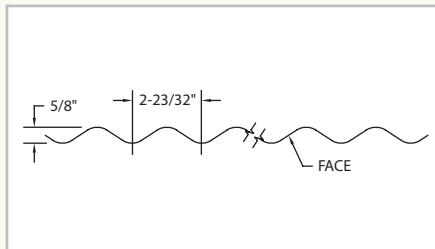

**PATTERN H**

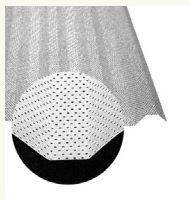
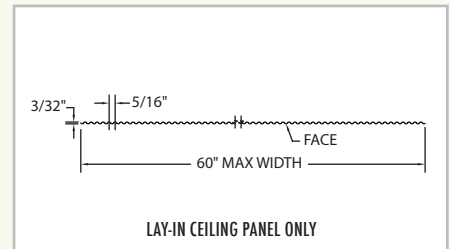

**PATTERN D**

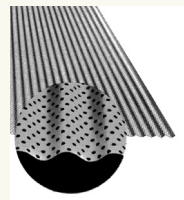
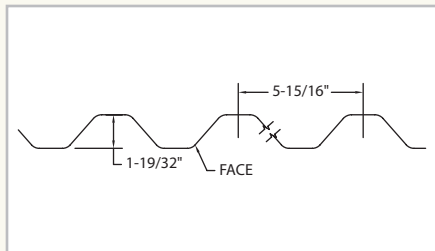

**PATTERN J**

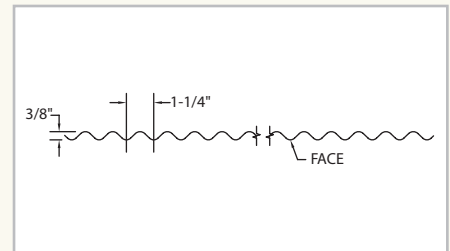

PANEL STANDARDS					
PATTERN	MAX. LENGTH	ALUMINUM THICKNESS	STEEL GAUGE		
			.032"	26G	24G
A	120"	x	x	x	
B	120"	x	x	x	x
C	144"	x	x*	x	x
D	120"	x	x	x	x
E	120"	x	x	x	
F	144"	x	x	x	
H	24"	x	x	x	
J	144"	x	x	x	x
MARK-7	120"	x	x	x	x

\*Call factory for dimensional limitations.

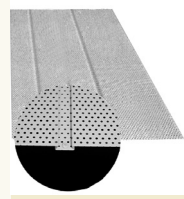

**MARK-7**

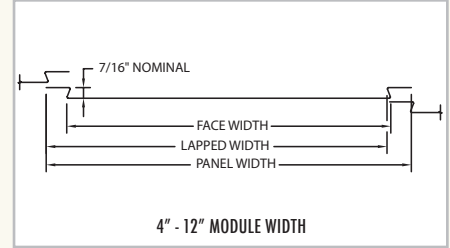

Standard Perforation Pattern is 0.125" (1/8") diameter holes on 0.328" (21/64") staggered centers; 13.2% open area. Custom Perforation Patterns are available. See our website for additional panel data.

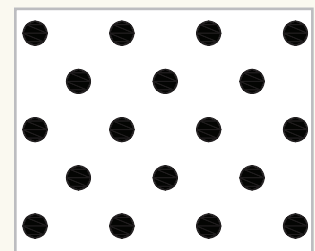

# ALPRO® ACOUSTICAL SYSTEMS

## METAL ACOUSTICAL WALL PANEL

ALPRO® designs and manufactures metal acoustical wall panel systems for field assembly that provide a wall covering that is decorative, functional, and durable. Wall panels, trim components, and exposed fasteners all have a matching powder coat finish, creating a uniform appearance.

### SYSTEM DESCRIPTION

- Perforated metal wall panels in 9 corrugation patterns: A-I; A-O; B; C; D; E-I; E-O; F; and J
- MARK-7 perforated metal linear panels
- “Z” furring strips typically installed on 24” centers
- Custom fit perimeter trims
- Sound absorbing material encapsulated in Polyethylene or PVC
- Factory painted screws for face attachment

### ACOUSTICAL PERFORMANCE

ALPRO acoustical wall systems achieve NRC test ratings to 1.00 (ASTM C-423). Acoustical performance varies when using sound control media having different thicknesses, densities, and encapsulating materials.



**BOK CENTER  
Tulsa, OK**

Wall Applications	Acoustical Pad		Encapsulating Material	Mounting Type	Frequency						NRC Rating
	Density	Thickness			125 Hz	250 Hz	500 Hz	1 KHz	2 KHz	4 KHz	
	1.5#	2 Inch			0.27	0.86	1.18	1.06	0.93	0.75	
			Black PVC	A (Flush)							

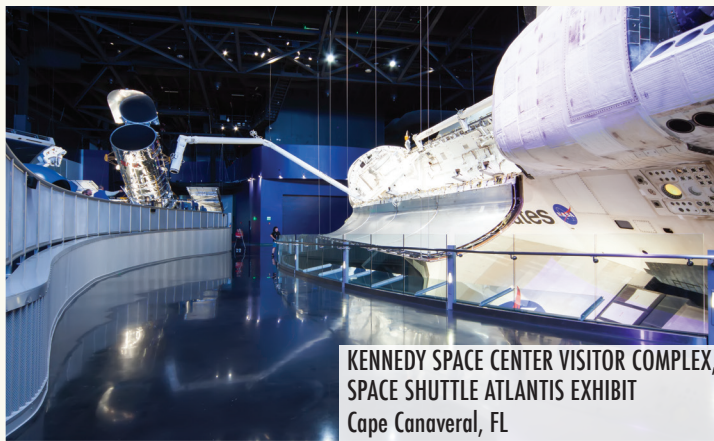

**KENNEDY SPACE CENTER VISITOR COMPLEX,  
SPACE SHUTTLE ATLANTIS EXHIBIT  
Cape Canaveral, FL**

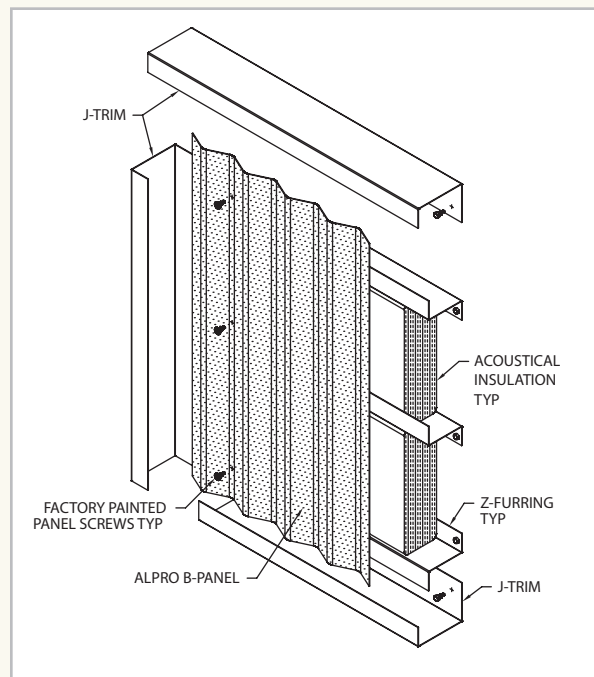
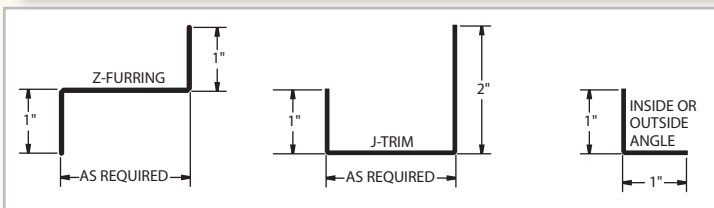

## METAL ACOUSTICAL WALL BAFFLES

ALPRO's acoustical wall baffles are factory assembled modular units, ideally suited for renovation and retrofit applications, as well as new construction. Wall baffles are commonly secured to the wall using flush mounts. Offset mounts may be used to improve absorption of intrusive noise and reduce reverberation time.

### CONSTRUCTION

- Perforated metal skins may be corrugated or flat
- Standard structural metal frames are 2" thick
- Acoustical media is 2" thick, 1.5# density fiberglass encapsulated Polyethylene or PVC
- Baffles ship complete with appropriate mounting hardware

### ACOUSTICAL PERFORMANCE

ALPRO modular wall baffles produced NRC test ratings to 1.15 (ASTM C-423).



Wall Baffle Applications	Acoustical Pad		Encapsulating Material	Mounting Type	Frequency						NRC Rating
	Density	Thickness			125 Hz	250 Hz	500 Hz	1 KHz	2 KHz	4 KHz	
	1.5#	2 Inch			Black PVC	D-100 (4" Offset)	0.86	1.02	1.00	1.08	
1.5#	2 Inch	Black PVC	A (Flush)	0.27	0.86	1.18	1.06	0.93	0.75	1.00	

### TYPICAL BAFFLE PROFILES

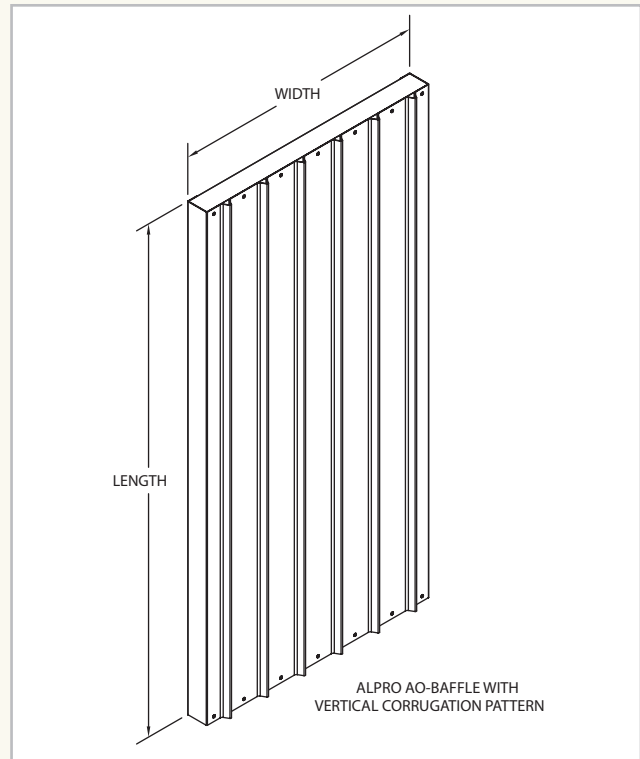
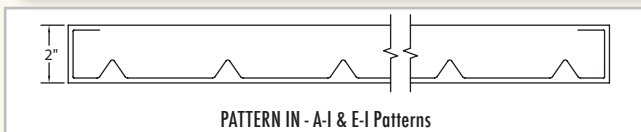

# ALPRO® ACOUSTICAL SYSTEMS

## METAL ACOUSTICAL PANEL CEILING SYSTEMS

ALPRO® acoustical ceiling systems provide attractive and effective noise reduction solutions. ALPRO furnishes perforated metal panels that are easily face attached to our extruded aluminum suspension grids.

### SYSTEM DESCRIPTION

- Perforated metal ceiling panels in 9 corrugation patterns: A-I; A-O; B; C; D; E-I; E-O; F; J
- MARK-7 perforated metal linear panels
- Extruded aluminum suspension grid systems
- Perimeter trims
- Sound absorbing material encapsulated in Polyethylene or PVC
- Factory painted screws for face attachment of panels

### ACOUSTICAL PERFORMANCE

ALPRO acoustical ceiling systems achieve NRC test ratings to 1.00 (ASTM C-423). Acoustical performance varies when using sound control media having different thicknesses, densities, and encapsulating materials.



**JAMES TAYLOR HIGH SCHOOL**  
Katy, TX

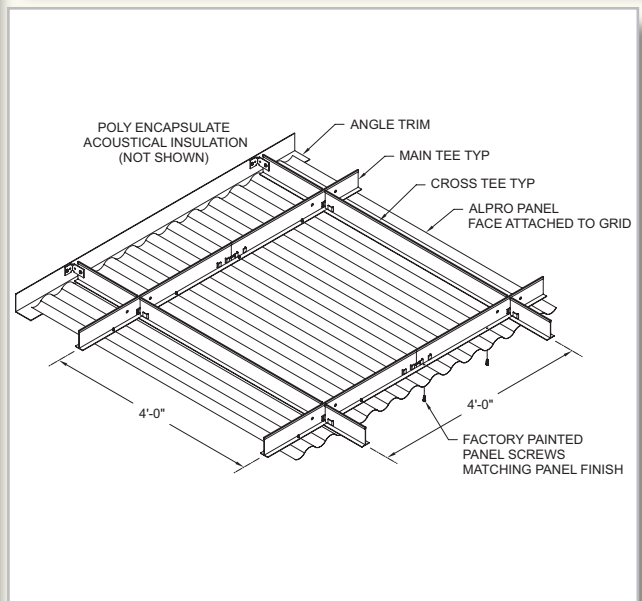

ALPRO's acoustical ceiling baffles are commonly used in open plenum spaces to provide effective acoustical performance and aesthetic interest. Baffles may be installed vertically or suspended horizontally to create a cloud effect.

**CONSTRUCTION**

- Perforated metal skins may be corrugated or flat
- Standard structural metal frames are 2" thick
- Acoustical media is 2" thick, 1.5# density fiberglass encapsulated in PVC
- Baffles ship complete with appropriate mounting hardware

**ACOUSTICAL PERFORMANCE**

ALPRO modular ceiling baffles produced NRC test ratings to 1.15 (ASTM C-423).



CISCA Construction Excellence Award Winner

McCARRAN INTERNATIONAL AIRPORT, CONSOLIDATED CAR RENTAL FACILITY Las Vegas, NV



WYOMING WWTP Wyoming, MI



LANCASTER HIGH SCHOOL, BAND ROOM Lancaster, NY



MASSACHUSETTS BAY TRANSPORTATION AUTHORITY, GOVERNMENT CENTER STATION, GREEN LINE PLATFORM Boston, MA

# ALPRO® ACOUSTICAL SYSTEMS

## LAY-IN METAL ACOUSTICAL PANEL CEILING SYSTEMS

ALPRO® lay-in metal acoustical ceiling panels are an affordable, functional, and aesthetically appealing alternative to composite acoustical panels. Lay-in metal panels provide a permanent, low maintenance ceiling surface offering acoustical values that are superior to panels made of other materials. Choose from 9 corrugations: A-I; A-O; B; C; E-I; E-O; F; J; including ALPRO's exclusive "H" pattern lay-in panel.



**JAMES TAYLOR HIGH SCHOOL**  
Katy, TX



**4' X 4' LAY-IN PANELS,**  
**PATTERN C**

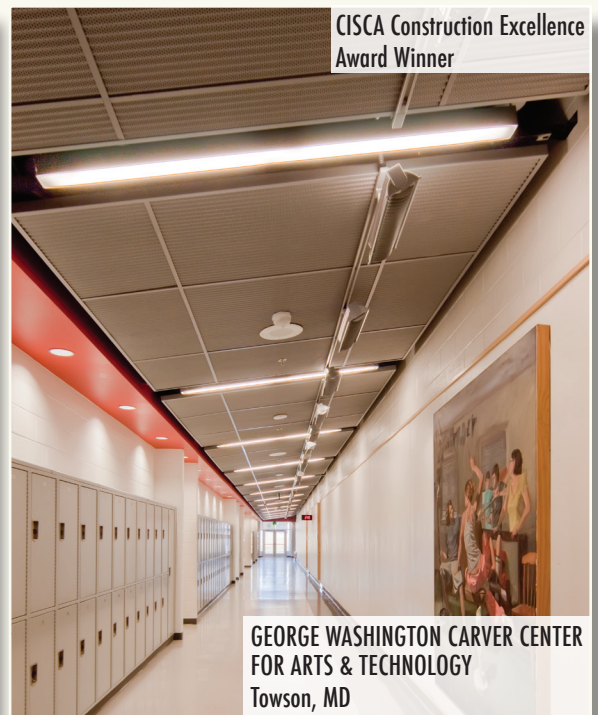
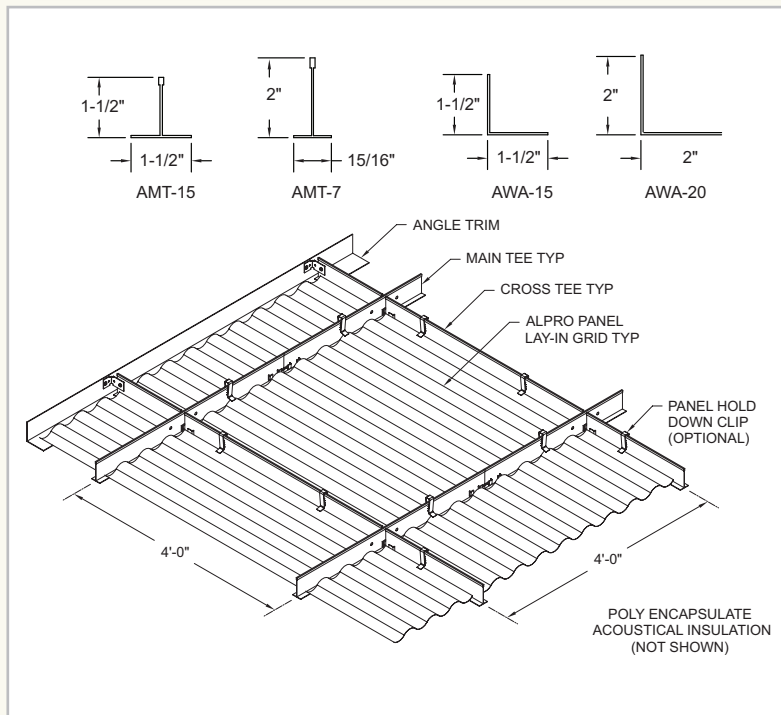

**CISCA Construction Excellence**  
**Award Winner**

**GEORGE WASHINGTON CARVER CENTER**  
**FOR ARTS & TECHNOLOGY**  
Towson, MD

Ceiling Applications	Acoustical Pad		Encapsulating Material	Mounting Type	Frequency					NRC Rating	
	Density	Thickness			125 Hz	250 Hz	500 Hz	1 KHz	2 KHz		4 KHz
	1.5#	2 Inch			Black PVC	E-400	0.86	1.02	1.00		1.08





# ALPRO® ACOUSTICAL SYSTEMS

## CUSTOM DESIGNED SYSTEMS

ALPRO® custom metal ceiling and wall systems are fully engineered and combine decorative expression with optimal acoustical performance.

- Concave, convex, sloped, undulating, or flat configurations
- Corrugated aluminum or steel panels
- Sound absorbing material
- Extruded aluminum suspension components
- Factory fabricated perimeter trims
- Lighting, Air Distribution, and FlexHead® sprinklers are among the features that may be integrated.

You are assured of perfect fit, consistent finish, and flawless color match of all components when you choose ALPRO as your single source provider.

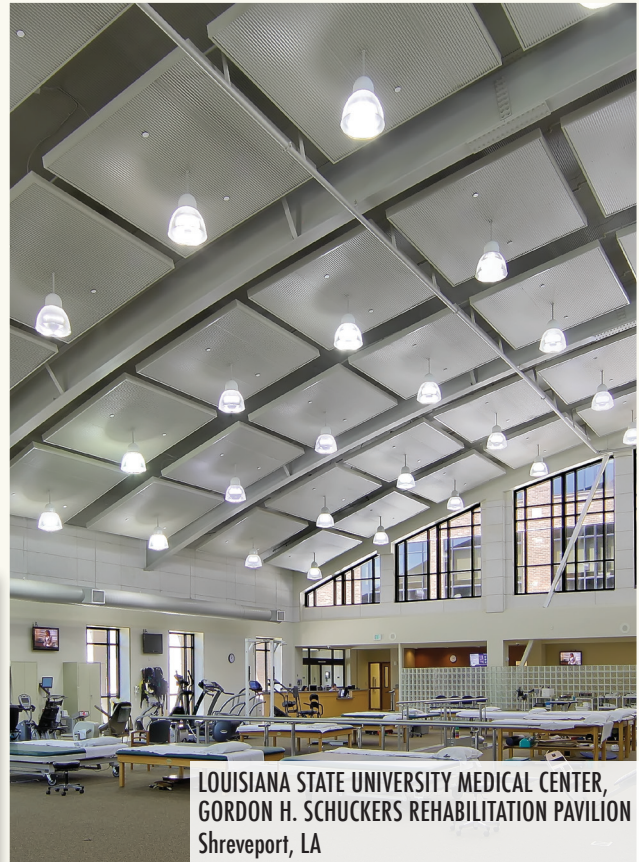

LOUISIANA STATE UNIVERSITY MEDICAL CENTER,  
GORDON H. SCHUCKERS REHABILITATION PAVILION  
Shreveport, LA



CISCA Construction Excellence  
Award Winner

WASHINGTON DULLES INTERNATIONAL AIRPORT,  
CONCOURSE C CONNECTOR TUNNEL  
Reston, VA



CARLSON HIGH SCHOOL  
Gibraltar, MI



DETROIT METRO AIRPORT  
Detroit, MI



IRON HILL BREWERY  
Lancaster, PA



MEADOWDALE MIDDLE SCHOOL  
Lynnwood, WA



T-MOBILE ARENA  
Las Vegas, NV

## GREEN BY DESIGN

- Products contribute to LEED®<sup>2</sup> certification
- Aluminum Coil - 22% recycled<sup>3</sup>
  - 18% pre-consumer content
  - 4% post consumer content
- Steel Coil - 63.5% recycled<sup>3</sup>
  - 10.8% pre-consumer content
  - 52.7% post consumer content
- In-House Finishes
  - Biodegradable pre-treatment (No phosphates)
  - No hazardous waste
  - No VOCs
  - No heavy metals
- Reference our sustainable products brochure and website for more information. Recycled content values are subject to change. Contact us for accurate values or job specific requirements.

**GORDON**<sup>®</sup>  
INCORPORATED

5023 HAZEL JONES ROAD, BOSSIER CITY, LA 71111  
800.747.8954  
800.877.8746 FAX  
SALES@GORDON-INC.COM  
GORDON-INC.COM  
AN EMPLOYEE OWNED COMPANY

<sup>1</sup> FlexHead® is a registered trademark of FlexHead Industries.

<sup>2</sup> LEED® is a registered trademark of the U.S. Green Building Council.

<sup>3</sup> Recycled Content values are subject to change. Contact factory for specific recycled content requirements.

